

 **MAVILOR**

INFRANOR GROUP COMPANY



Motors

ISSUE 2001

AC Servo Motors BL 110/140/190 Series

The BL Series are synchronous electrical servomotors, with 3 winding phases, supplied with Sinusoidal or Trapezoidal current wave forms. The Feed-Back devices that produce the synchronization signal and speed (position, also in the Sinusoidal case), are a Resolver (BLS Series) or a Hall effect devices (BLT Series). This "BRUSHLESS" technology provides:

- High dynamic response.
- Full speed condition, not limited by the "Brush Sparking effect".
- High thermal and dynamic characteristics, because of the motor's windings which are located in the stators.
- Very low maintenance.
- Connection box with four available positions from the standard construction.

BLS ~ Technical Specifications

ALL CHARACTERISTICS MEASURED
AT 25° C AMBIENT TEMPERATURE

SYMBOLS UNITS

	SYMBOLS	UNITS
MAX MECHANICAL SPEED	n	rpm
STALL TORQUE ⁽¹⁾ ±10%	M _S	Nm
STALL CURRENT	I _S	A
PEAK TORQUE ±10%	M _J	Nm
TORQUE-WEIGHT RATIO	T _W	Nm/kg
EMF CONSTANT ±5%	K _E	Vs/rad
TORQUE CONSTANT ±5%	K _T	Nm/A
RELUCTANCETORQUE ^(*)	T _R	Nm
WINDING RESISTANCE ±5%	R	Ω
WINDING INDUCTANCE ±5%	L	mH
ROTOR INERTIA	J	kg m ² 10 ⁻³
MECHANICAL TIME CONSTANT	T _M	ms
ELECTRICAL TIME CONSTANT	T _E	ms
THERMAL TIME CONSTANT	T _{TH}	s
THERMAL RESISTANCE	R _{TH}	°C/W
MASS	M	kg
RADIAL LOAD (at mid-length of shaft)	F _R	N
AXIAL LOAD	F _A	N
INSULATION		
PROTECTION		

(1) With an aluminium heat sink plate

(*) Respect to the Stall Torque



MAX MECHANICAL SPEED
STALL TORQUE ⁽¹⁾ ±10%
STALL CURRENT
PEAK TORQUE ±10%
TORQUE-WEIGHT RATIO
EMF CONSTANT ±5%
TORQUE CONSTANT ±5%
RELUCTANCETORQUE

BLS-111		BLS-112		BLS-113		BLS-114		BLS-115	
220 VAC	400 VAC	220 VAC	400 VAC	220 VAC	400 VAC	220 VAC	400 VAC	220 VAC	400 VAC
8,500		8,500		8,500		8,500		8,500	
2.9	2.9	5.0	5.0	8.4	8.4	10.6	10.6	13.9	13.9
3.49	2.04	6.02	3.29	9.88	5.71	12.77	7.31	17.16	9.79
11.6	11.6	20.0	20.0	33.6	33.6	42.4	42.4	55.6	55.6
0.73	0.73	1.0	1.0	1.33	1.33	1.43	1.43	1.64	1.64
0.48	0.82	0.48	0.88	0.49	0.85	0.48	0.84	0.47	0.82
0.83	1.42	0.83	1.52	0.85	1.47	0.83	1.45	0.81	1.42
<3%		<3%		<3%		<3%		<3%	
7.2	20.6	2.4	7.1	1.3	3.79	0.8	2.58	0.6	1.84
10	31	4.8	13.2	2.7	8.5	1.9	5.8	1.5	5.1
0.2	0.2	0.38	0.38	0.56	0.56	0.74	0.74	0.93	0.93
3.61	3.54	2.29	2.02	1.75	1.70	1.49	1.57	1.47	1.47
1.39	1.5	2.0	1.86	2.08	2.24	2.38	2.25	2.5	2.77
2,520	2,520	1,910	1,910	2,260	2,260	2,510	2,510	3,700	3,700
0.65	0.67	0.66	0.75	0.45	0.46	0.44	0.42	0.32	0.33
4	4	5	5	6.3	6.3	7.4	7.4	8.5	8.5
515		515		515		515		515	
255		255		255		255		255	
CLASS-F		CLASS-F		CLASS-F		CLASS-F		CLASS-F	
IP-65		IP-65		IP-65		IP-65		IP-65	
400x400x10									

BLS-141		BLS-142		BLS-143		BLS-144	
220 VAC	400 VAC	220 VAC	400 VAC	220 VAC	400 VAC	220 VAC	400 VAC
6,500		6,500		6,500		6,500	
13.6	13.6	17.4	17.4	26.8	26.8	33	33
13.6	7.01	15.4	8.02	19.14	10.19	17.55	9.38
54.4	54.4	69.6	69.6	107.2	107.2	132.0	132.0
1.3	1.3	1.41	1.41	1.63	1.63	1.64	1.64
0.58	1.12	0.65	1.25	0.81	1.52	1.09	2.03
1	1.94	1.13	2.17	1.4	2.63	1.88	3.52
<2.5%		<2.5%		<2.5%		<2.5%	
0.86	2.9	0.73	2.46	0.63	2.04	0.74	2.5
2.8	11.5	2.6	9	2.7	9.6	3.2	11
1.71	1.71	2.34	2.34	3.34	3.34	4.59	4.59
2.54	2.28	2.33	2.12	1.86	1.70	1.66	1.61
3.26	3.97	3.56	3.66	4.29	4.71	4.32	4.4
3,740	3,740	4,500	4,500	4,626	4,626	4,800	4,800
0.36	0.40	0.33	0.36	0.25	0.27	0.25	0.26
10.5	10.5	12.3	12.3	16.4	16.4	20.1	20.1
784		784		784		784	
343		343		343		343	
CLASS-F		CLASS-F		CLASS-F		CLASS-F	
IP-65		IP-65		IP-65		IP-65	
700x700x20							

BLS-191	BLS-192
400 VAC	400 VAC
2,800	
56	82
25.11	34.60
224.0	328.0
1.9	2.1
1.29	1.37
2.23	2.37
<2%	
0.39	0.26
1.9	1.5
14.7	22
1.99	1.76
4.87	5.77
4,400	4,090
0.23	0.18
29.5	39
1,400	
690	
CLASS-F	
IP-65	
700x700x20	

BLT-111		BLT-112		BLT-113		BLT-114		BLT-115	
220 VAC	400 VAC	220 VAC	400 VAC	220 VAC	400 VAC	220 VAC	400 VAC	220 VAC	400 VAC
8,500		8,500		8,500		8,500		8,500	
2.9	2.9	5.0	5.0	8.4	8.4	10.6	10.6	13.9	13.9
4.33	2.5	7.46	4.03	12.17	7.0	15.82	8.98	21.06	11.98
11.6	11.6	20.0	20.0	33.6	33.6	42.4	42.4	55.6	55.6
0.73	0.73	1.01	1.01	1.34	1.34	1.44	1.44	1.64	1.64
0.67	1.16	0.67	1.24	0.69	1.2	0.67	1.18	0.66	1.16
0.67	1.16	0.67	1.24	0.69	1.2	0.67	1.18	0.66	1.16
<3%		<3%		<3%		<3%		<3%	
7.2	20.6	2.4	7.1	1.3	3.79	0.8	2.58	0.6	1.84
10	31	4.8	13.2	2.7	8.5	1.9	5.8	1.5	5.1
0.2	0.2	0.38	0.38	0.56	0.56	0.74	0.74	0.93	0.93
3.21	3.06	2.03	1.75	1.53	1.47	1.32	1.37	1.28	1.27
1.39	1.5	2.0	1.86	2.08	2.24	2.38	2.25	2.5	2.77
2,520	2,520	1,910	1,910	2,260	2,260	2,510	2,510	3,700	3,700
0.64	0.67	0.64	0.75	0.45	0.46	0.43	0.41	0.32	0.33
3.97	3.97	4.97	4.97	6.27	6.27	7.37	7.37	8.47	8.47
515		515		515		515		515	
255		255		255		255		255	
CLASS-F		CLASS-F		CLASS-F		CLASS-F		CLASS-F	
IP-65		IP-65		IP-65		IP-65		IP-65	
400x400x10									

BLT-141		BLT-142		BLT-143		BLT-144	
220 VAC	400 VAC	220 VAC	400 VAC	220 VAC	400 VAC	220 VAC	400 VAC
6,500		6,500		6,500		6,500	
13.6	13.6	17.4	17.4	26.8	26.8	33	33
16.59	8.61	18.91	9.89	23.51	12.47	21.43	11.5
54.4	54.4	69.6	69.6	107.2	107.2	132.0	132.0
1.3	1.3	1.42	1.42	1.64	1.64	1.64	1.64
0.82	1.58	0.92	1.76	1.14	2.15	1.54	2.87
0.82	1.58	0.92	1.76	1.14	2.15	1.54	2.87
<2.5%		<2.5%		<2.5%		<2.5%	
0.86	2.9	0.73	2.46	0.63	2.04	0.74	2.5
2.8	11.5	2.6	9	2.7	9.6	3.2	11
1.71	1.71	2.34	2.34	3.34	3.34	4.59	4.59
2.19	1.99	2.02	1.86	1.62	1.47	1.43	1.39
3.26	3.97	3.56	3.66	4.29	4.71	4.32	4.4
3,740	3,740	4,500	4,500	4,626	4,626	4,800	4,800
0.36	0.4	0.33	0.36	0.25	0.27	0.25	0.26
10.47	10.47	12.27	12.27	16.37	16.37	20.7	20.7
784		784		784		784	
343		343		343		343	
CLASS-F		CLASS-F		CLASS-F		CLASS-F	
IP-65		IP-65		IP-65		IP-65	
700x700x20							

BLT-191	BLT-192
400 VAC	400 VAC
2,800	
56	82
30.43	42.49
224.0	328.0
1.9	2.1
1.84	1.93
1.84	1.93
<2%	
0.39	0.26
1.9	1.5
14.7	22
1.69	1.54
4.87	5.77
4,400	4,090
0.24	0.18
29.47	38.97
1,400	
690	
CLASS-F	
IP-65	
700x700x20	

AC Servo Motors BL 110/140/190 Series

Performance Curves

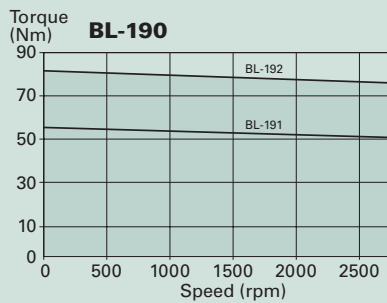
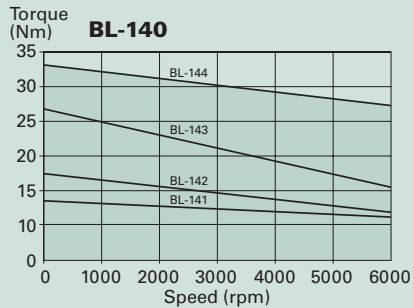
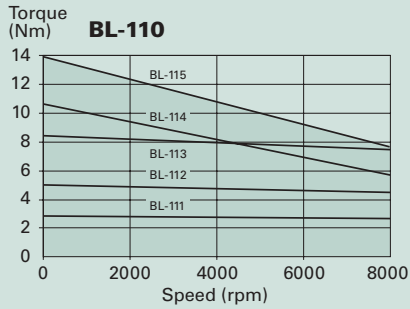

Resolver Specifications

	UNITS	2T8 (Transmitter Speed 1)
Input Voltage/Frequency	V/kHz	10/4.5
Primary Element		Rotor
Number of Speed		1X
Transformation Ratio		0.5 ± 5%
Electrical Error	minutes	±10 max.
Dielectric Strength	VAC/1 minute	500
Mass	kg	0.230
Rotor Moment of Inertia	kg m ² 10 ⁻³	0.0123
Operating Temperature Range	°C	-55 ~ +155

Brake Specifications

	SIZE	TORQUE Nm	INERTIA kg cm ²	MASS kg
BL-111 / 112	10	8	0.30	0.8
BL-113 / 114 / 115	10	12	0.30	0.8
BL-141 / 142 / 143 / 144	11	20	9.5	1.9
BL-191 / 192	09	72	16	2.85

The BL Series incorporates the option of a fail-safe holding brake within the structure of the motor.

Optional Accessories

MSS Encoder Kit (no encoder)

	I
MSS-2	235
MSS-4	233
MSS-6	233
MSS-8	243.5
MSS-12	237.5
MSS-22	265.5
MSS-35	291
MSS-45	291

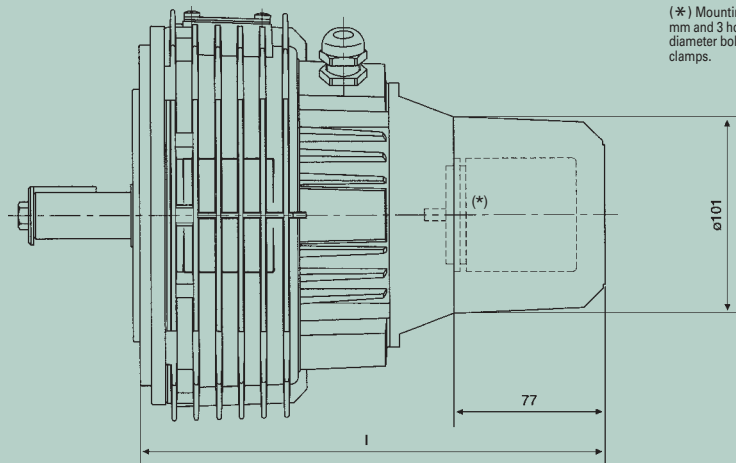

(*) Mounting pilot of 50 mm and 3 holes M4 on a 67,3 diameter bolt circle for fixing clamps.

MA Encoder Kit (no encoder)

	A
MA-6	237.5
MA-10	237.5
MA-20	252.5
MA-30	261.5
MA-45	274
MA-55	274

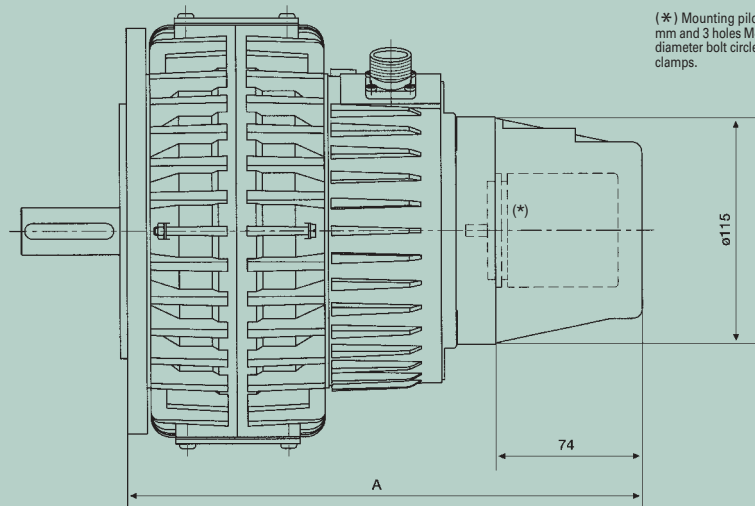

(*) Mounting pilot of 50 mm and 3 holes M4 on a 67,3 diameter bolt circle for fixing clamps.

BL 110/140 Encoder Kit (no encoder)

	A
BL-111	282
BL-112	307
BL-113	332
BL-114	357
BL-115	382
BL-141	346
BL-142	367
BL-143	411
BL-144	453

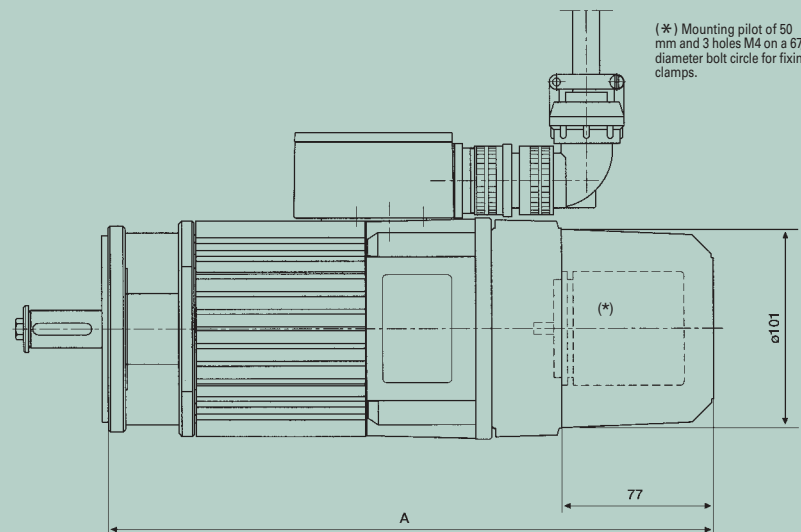

(*) Mounting pilot of 50 mm and 3 holes M4 on a 67,3 diameter bolt circle for fixing clamps.